



VALVES

BALL - BRASS
UL 600 WOG/CWP

FEATURES & APPLICATIONS:

- Standard Port - 2 Piece
- UL 600 WOG/CWP
- Plumbing or heating projects, low pressure steam, compressed air, HVAC

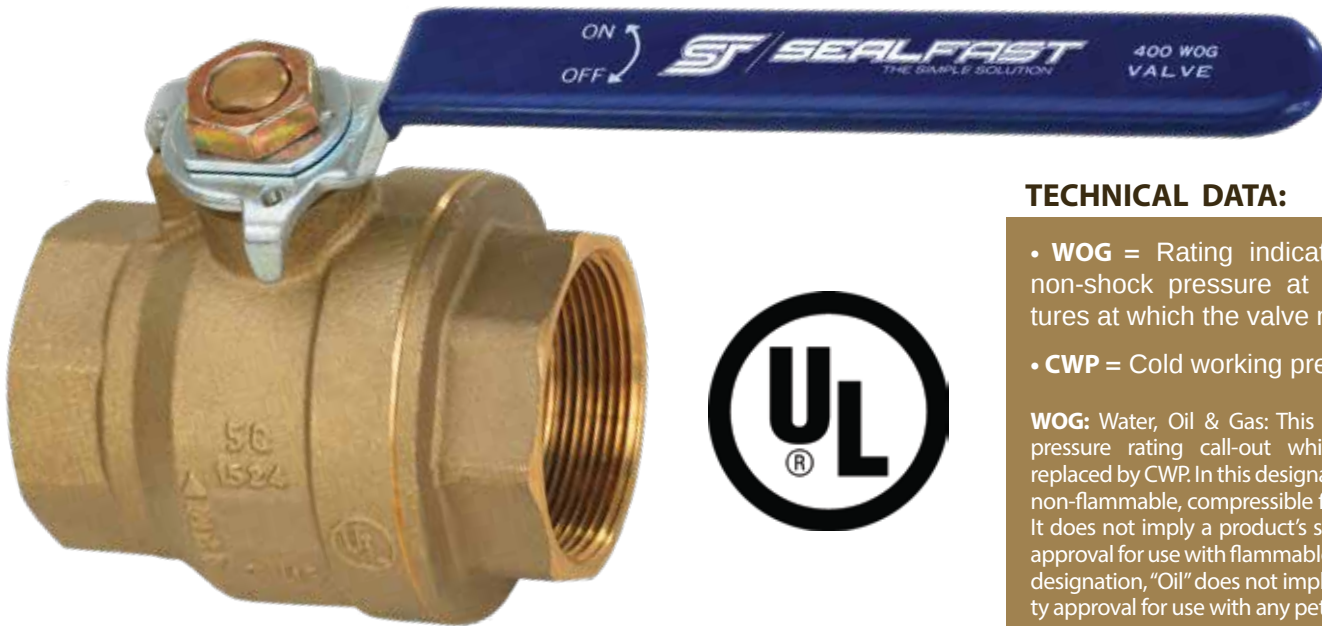

TECHNICAL DATA:

- **WOG** = Rating indicates the maximum non-shock pressure at ambient temperatures at which the valve may be used.
- **CWP** = Cold working pressure

WOG: Water, Oil & Gas: This was an older, generic pressure rating call-out which has been largely replaced by CWP. In this designation, "GAS" refers to any non-flammable, compressible fluid in a gaseous state. It does not imply a product's suitability or third-party approval for use with flammable gases. Similarly, in this designation, "Oil" does not imply a product's third-party approval for use with any petroleum products.

BRASS	
Size	Part #
1/4"	BFV 025
3/8"	BFV 038
1/2"	BFV 050
3/4"	BFV 075
1"	BFV 100
1-1/4"	BFV 125
1-1/2"	BFV 150
2"	BFV 200

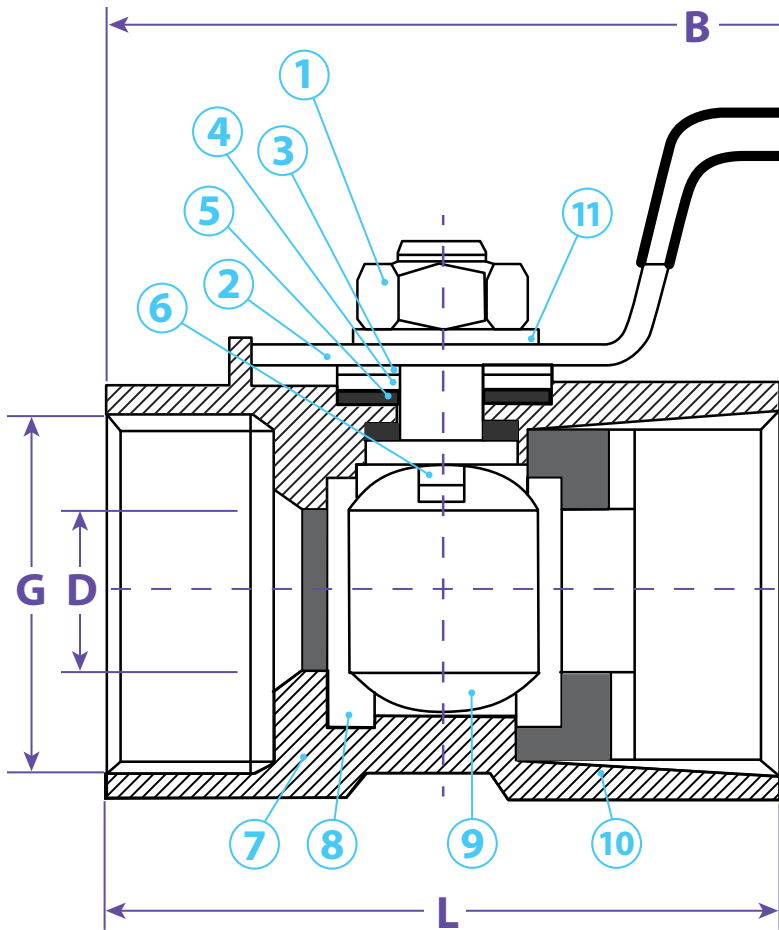

• Non-Locking Handle

Nomenclature & Material

No.	Description	Material	Specs JIS	Specs ASTM
1	Nut	Brass	C3604BE	B16-C36000
2	Handle	Steel	SS41	A283-D
3	Stem Gland Screw	Brass	C3604BE	B16-C36000
4	Stem Packing	Teflon	PTFE	PTFE
5	Thrust Packing	Teflon	PTFE	PTFE
6	Stem	Brass	C3604BE	B16-C36000
7	Body	Forged Brass	C3771BE	B124-C37700
8	Ball Disc Packing	Teflon	PTFE	PTFE
9	Ball Disc	Brass	C3771BE C3604BE	B124-C37700 B16-C36000
10	End Plug	Forged Brass	C3771BE	B124-C37700
11	Spring Washer	Hard Steel Wire	SWRH52	

Dimensions

Size	G	B	H	D	L	Part #
1/4"	1/4" NPT	3.15	1.50	.35	1.57	BFV 025
3/8"	3/8" NPT	3.15	1.61	.39	1.52	BFV 038
1/2"	1/2" NPT	3.54	1.81	.55	1.87	BFV 050
3/4"	3/4" NPT	3.54	2.13	.75	2.17	BFV 075
1"	1" NPT	4.33	2.17	.87	2.44	BFV 100
1-1/4"	1-1/4" NPT	5.12	2.56	1.14	2.91	BFV 125
1-1/2"	1-1/2" NPT	5.43	2.95	1.46	3.31	BFV 150
2"	2" NPT	7.13	3.35	1.77	3.86	BFV 200

Temperature / Pressure Rating

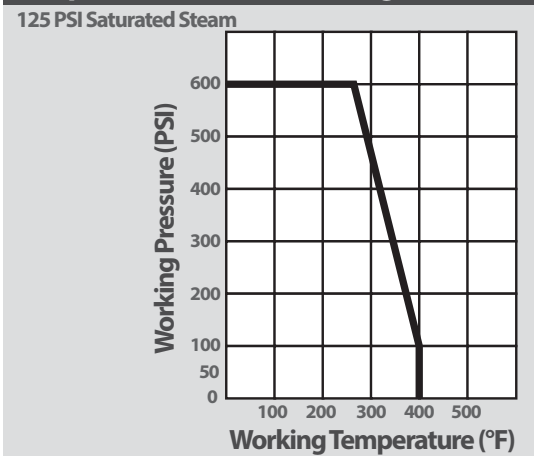

TITLE **BALL VALVE - UL 600 WOG/CWP**

DISCLAIMER

All drawings and specifications are subject to change without notice. Drawings represent general dimensions of our products. Seal Fast cannot guarantee the dimensions of the part will exactly match those in the drawing. This drawing is the property of Seal Fast Inc. Copying or reproduction of this drawing is expressly prohibited.

MATERIAL

BRASS

DRAWING NOT TO SCALE

PART #

BFV...